

CAT X PRESS

The CAT-Xpress spray gun offers both a pressure reduced air cap (2403218 & 2403224) and HVLP air cap (2403233 & 2403235) for areas requiring HVLP compliance.

2403218 & 2403224

- Consumes 9 cfm at 29 psi gun inlet
- Pressure reduced
- 2403218 - can be used with 0.8 mm - 1.8 mm orifices
- 2403224 - can be used with 2.0 mm - 2.2 mm orifices

2403233 & 2403235

- Consumes 9 cfm at 26 psi gun inlet
- For areas requiring HVLP compliance.
- 2403233 - can be used with 0.8 mm - 1.8 mm orifices
- 2403235 - can be used with 2.0 mm - 2.2 mm orifices

HVLP/Pressure reduced air cap and fluid nozzle chart

| Pressure reduced air cap | SCFM @ max gun inlet pressure | HVLP air cap | SCFM @ max gun inlet pressure for HVLP | Fluid tip range | Orifice size | Fluid tip part number | Fluid needle part number |
|--------------------------|-------------------------------|--------------|--|------------------|--------------|-----------------------|--------------------------|
| 2403218 | 9 CFM @ 29 PSI | 2403233 | 9 CFM @ 26 PSI | 0.8 mm to 1.8 mm | 0.8 mm | 2404488 | 2397054 |
| | | | | | 1.0 mm | 2404489 | 2397055 |
| | | | | | 1.2 mm | 2404491 | 2397056 |
| | | | | | 1.3 mm | 2412850 | 2412848 |
| | | | | | 1.4 mm | 2397074 | 2397057 |
| | | | | | 1.5 mm | 2404492 | 2397058 |
| | | | | | 1.8 mm | 2404493 | 2397059 |
| 2403224 | 9 CFM @ 29 PSI | 2403235 | 9 CFM @ 26 PSI | 2.0 mm | 2.0 mm | 2404494 | 2397060 |
| | | | | 2.2 mm | 2.2 mm | 2404495 | 2397061 |

Actual fluid nozzle and air cap combinations are determined by application (see application chart page 4)

*Gun inlet pressures may vary as required by application

*Smaller and larger nozzle sizes are available upon request

Operation and Maintenance Instructions for CAT-Xpress Spray Guns

Operation

1. Connect air supply hose at handle of gun.
2. Connect a pressurized fluid supply to the gun fluid inlet.
3. Fluid flow can be controlled using the fluid control knob, this restricts flow by limiting needle travel. It is best to control fluid flow by proper selection of fluid orifice size and use the fluid control knob to "fine tune flow rate".
4. Fan width can be adjusted using the fan control knob. Turning the knob clockwise narrows the fan.

Maintenance

IMPORTANT! Routine cleaning and maintenance is essential to insure proper gun operation. Several states prohibit spraying solvent into the atmosphere and require the use of covered gun cleaner.

1. If a gun cleaner is being used, connect and clean the gun in the gun cleaner according to the manufactures instructions.
2. If a gun cleaner is not being used:
Remove air cap and clean separately using clean solvent. For pressure setups, connect a pressurized solvent supply to the fluid inlet, trigger the gun allowing solvent to flow thru the gun until clean.

NOTE: Gun head disassembly is not recommended for normal cleaning and maintenance.

Gun head disassembly and reassembly instructions:
Have repair kit # 2411779 available before gun disassembly.

Gun head disassembly

To remove the nozzle carrier (8):

1. Remove the air cap (1 & 4), fluid nozzle body (5), baffle (6), fluid nozzle (7), and needle (26).
2. Remove the needle seal cartridge (10).
3. Loosen the locknut (12) and remove fluid inlet (13) using a 5/8" open-end wrench.
4. The nozzle carrier (8) and o-ring (9) will now slide forward from the gun body (40).

Gun head reassembly

1. Install a new o-ring (9) on the fluid nozzle body carrier (8).
2. Install the thread locknut (12) onto the fluid inlet (13) as far as possible.
3. Install a new fluid inlet seal (11) into the recess area on the fluid nozzle body carrier (8) inlet port.
4. Slide the fluid nozzle body carrier (8) into the gun body (40) as far as possible. Be sure the fluid nozzle body carrier (8) extends into the hole at the back of the gun head. Install the needle seal (10) but do not tighten.
5. Rotate the fluid nozzle body carrier (8) until the fluid inlet port in the nozzle body carrier (8) is aligned with the threaded hole in the gun body (40). While in this position, insert the fluid inlet (13) and tighten firmly. Locknut (12) should already be threaded onto the fluid inlet (13).
6. Tighten the needle seal (10) to approx. 12 ft.-lb. torque.
7. Tighten the fluid inlet (13) to approx. 25 ft.-lb. torque.
8. Tighten the locknut (12) to approx. 33 ft.-lb. torque.
9. Install baffle (6) into gun body (40) with the holes facing inward towards the gun body. Make sure to line up to pins.
10. Install fluid nozzle (7) into nozzle body (5), then thread and tighten into fluid nozzle body carrier (8).
11. Install air cap (4) into the air cap ring (1). Sealing ring (2) and o-ring (3) should already be installed in the air cap ring (1). then thread onto the gun body's (40) head assembly.

Fan control disassembly

To remove the fan control (29):

1. Remove the rear fluid adjustment knob assembly (36 - 39) along with the fluid needle (28).
2. Make sure the fan adjustment knob (32) is in the open position (turned counter clockwise when pointed away from you).
3. Please note step 4 and back out the fan control sleeve (35) counter clockwise.
4. As you back out the fan control sleeve (35), the housing (31) will want to move inward into the body. When this happens, alternate between turning the adjustment knob (32) counter clockwise and backing out the control sleeve (35). Repeat until the fan control assembly fully backs out.

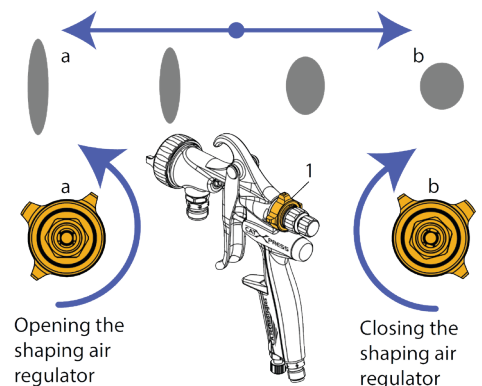

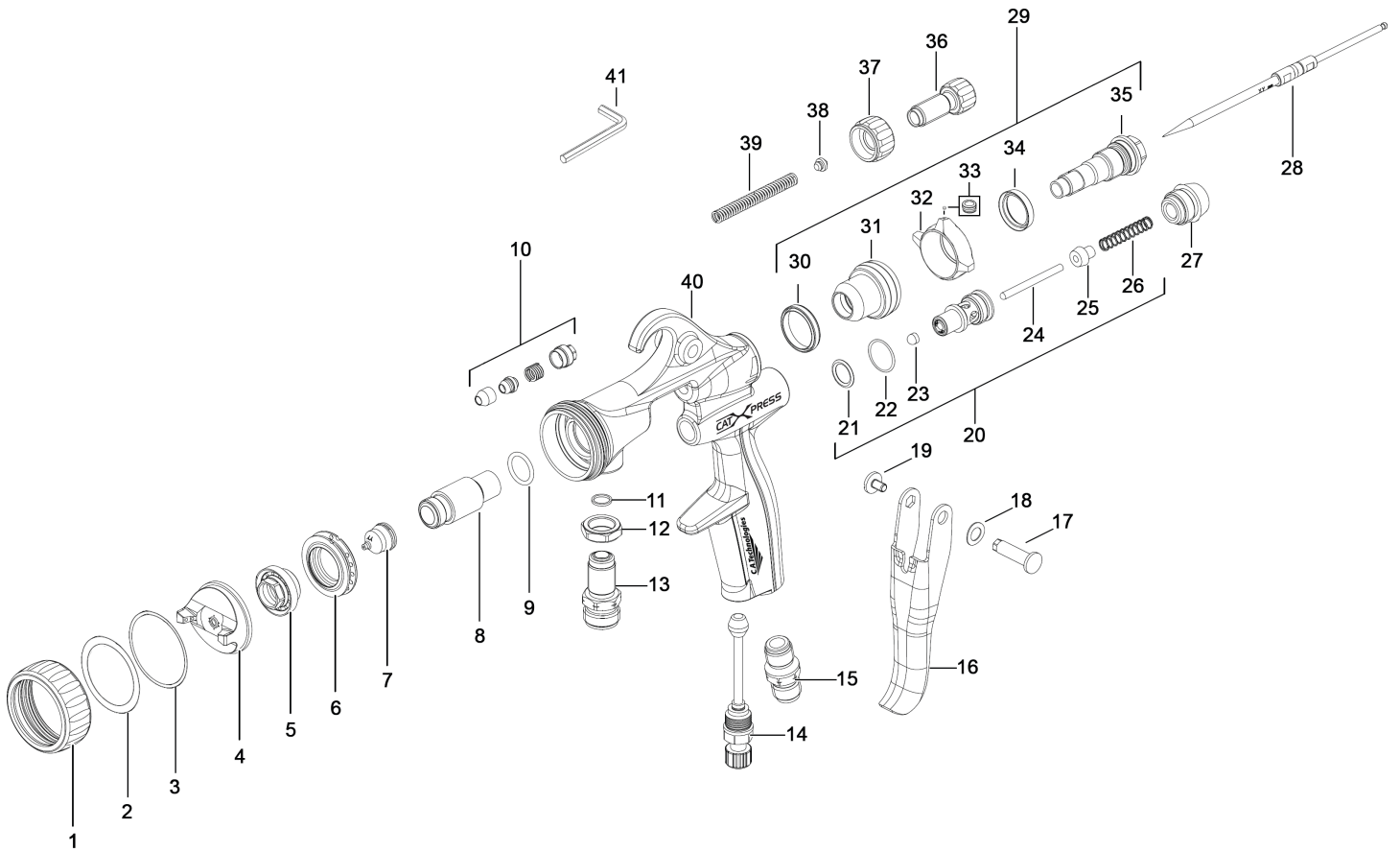

| Item no. | K | Part no. | Description | Item no. | K | Part no. | Description |
|----------|----|-------------------------|---------------------------|----------|----|------------------------|----------------------------|
| 1 | | 2400154 | Air Cap Ring | 22 | * | 98-5125 | O-Ring |
| 2 | * | V2070005300 | Air Cap Sealing Ring | 23 | * | 2396036 | Air Valve Stem Cap |
| 3 | * | V2070005200 | O-Ring | 24 | | 60-1371 | Air Valve Stem |
| 4 | ** | See Air Cap Chart (Pg1) | Air Cap | 25 | | 61-1032 | Air Valve Poppet |
| 5 | | 2394821 | Nozzle Body | 26 | * | 61-1003 | Air Valve Spring |
| 6 | | 2394820 | Air Baffle | 27 | | 60-1375 | Rear Cap |
| 7 | ** | See Nozzle Chart (Pg1) | Fluid Nozzle | 28 | ** | See Needle Chart (Pg1) | Fluid Needle |
| 8 | | 2396024 | Fluid Nozzle Body Carrier | 29 | | 2403453 | Fan Control Assembly |
| 9 | * | 98-8014 | O-Ring | 30 | | 2396032 | Fan Control Rod Seal |
| 10 | * | 2400771 | Needle Packing Assembly | 31 | | 2403413 | Fan Adjustment Housing |
| 11 | * | 2396026 | Fluid Inlet Sealing Ring | 32 | | 2403416 | Fan Adjustment Knob |
| 12 | | 60-128 | Lock Nut | 33 | | 2403429 | Fan Adjustment Knob Screw |
| 13 | | 2396785 | Fluid Inlet | 34 | | 2316489 | Fan Control Seal |
| 14 | | 60-1319 | Air Control Knob | 35 | | 2403412 | Fan Control Sleeve |
| 15 | | 60-104 | Air Inlet | 36 | | 2396038 | Fluid Adjustment Knob |
| 16 | | 2396021 | Trigger | 37 | | 2396039 | Fluid Adjustment Lock Nut |
| 17 | | 2396019 | Trigger Pin | 38 | * | 2396035 | Needle Spring Guide |
| 18 | | V1070111100 | Spring washer | 39 | * | 2396050 | Needle Spring |
| 19 | | V1030109000 | Trigger Screw | 40 | | 2410599 | Gun Body |
| 20 | | 2400772 | Air Valve (Complete) | 41 | | 2412114 | 1/16" Allen Wrench for #33 |
| 21 | * | 98-8012 | O-Ring | | | | |

*Indicates part included in repair kit # 2411779

**See air cap selection chart on page 1

Fluid nozzle / Air cap selection charts

CAT-Xpress Series - Pressure Feed Guns

CAT-Xpress HVLP/Pressure reduced spray gun

| Material type | Fluid orifice x Air cap | Maximum pattern width | CFM |
|---|--|----------------------------|--------------------------------|
| Very Thin less than 16 sec. Zahn #2 inks , dyes, solvents, stains | 0.8 mm x 2403218 or 2403233 1.0 mm x 2403218 or 2403233 | 2403218 13" 2403233 12" | 2403218 9 CFM 2403233 9 CFM |
| Thin 16 to 20 sec. Zahn #2 lacquers, enamels, primers, sealers | 1.2 mm x 2403218 or 2403233 1.3 mm x 2403218 or 2403233 | 2403218 13" 2403233 12" | 2403218 9 CFM 2403233 9 CFM |
| Medium 21 to 30 sec. Zahn #2 automotive base coat enamels, primers epoxies, urethanes automotive clear coat | 1.2 mm x 2403218 or 2403233 1.3 mm x 2403218 or 2403233 1.5 mm x 2403218 or 2403233 1.8 mm x 2403218 or 2403233 | 2403218 13" 2403233 12" | 2403218 9 CFM 2403233 9 CFM |
| Heavy over 30 sec. Zahn #2 heavy body primers high solid enamels high solid automotive coatings adhesives | 1.8 mm x 2403224 or 2403235 2.0 mm x 2403224 or 2403235 2.2 mm x 2403224 or 2403235 2.5 mm x 2403224 or 2403235 | 2403224 13" 2403235 12" | 2403224 9 CFM 2403235 9 CFM |

CAT-XPR Includes:

CAT-Xpress
 Air Caps
 Nozzle/Needle Sets
 60-8002 Gun Wrench
 98-0113 Gun Cleaning Brush
 2412114 Allen Wrench (1/16")

CAT-XPR-303R2 Includes:

CAT-Xpress
 Air Caps
 Nozzle/Needle Sets
 51-303-R2 1 QT Aluminum Cup
 52-5R2 Regulator
 60-8002 Gun Wrench
 98-0113 Gun Cleaning Brush
 2412114 Allen Wrench (1/16")

CAT-XPR-PPSR2 Includes:

CAT-Xpress
 Air Caps
 Nozzle/Needle Sets
 CA91-560 850 mL PPS™ Pressure Cup
 CA91-562 Lids and Liners (Available in 25 Pack)
 CA91-575 #18 PPS Adapter
 52-5R2 Regulator
 60-8002 Gun Wrench
 98-0113 Gun Cleaning Brush
 2412114 Allen Wrench (1/16")

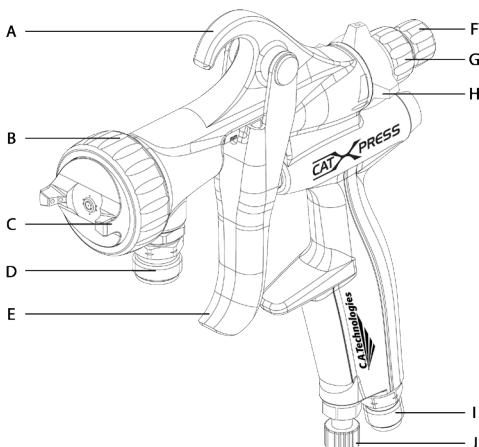

| Pos. | Designation |
|------|------------------------------|
| A | Suspension Hook |
| B | Air Cap Ring |
| C | Air Cap |
| D | Fluid Inlet |
| E | Trigger |
| F | Needle Stroke Regulator |
| G | Needle Stroke Regulator Lock |
| H | Fan Air Control |
| I | Air Inlet Connection |
| J | Air Regulation Knob |

C.A. Technologies - Division of the Wagner Group

Liquid Division
 337 South Arthur Ave
 Louisville, CO 80027
 T 888.820.4498
 F 303.438.5708

www.spraycat.com

WAGNER GROUP